



City of Fruitland Building Inspections
208 South Division Street
Fruitland, Maryland 21826
410.548.2804

CITY OF FRUITLAND DIVISION OF PLAN REVIEW & PERMITTING DECK GUIDE

GENERAL NOTES

- This design guide assumes all lumber to be pressure-treated Southern Pine.
- Manufactured decking, railing and composite products (plastic, fiberglass, etc.) are permitted if installed per the manufacturer's product specifications. These products must have an approved building code evaluation report. The manufacturer's instructions and evaluation report shall be provided on the job site.
- Chemicals used in pressure treated lumber will prematurely corrode standard fasteners, hardware and flashing. All screws and nails shall be hot-dipped galvanized or stainless steel. All hardware (joist hangers, cast-in-place post anchors, etc.) shall be galvanized or stainless steel.
- Decks constructed according to this handout are not approved for future hot tub installations. Deck loads exceeding the minimum 40 psf live load such as hot tubs, spas or other concentrated loads shall require a design certification from a Maryland licensed professional engineer.
- Two copies of plans are required and shall include post size and spacing, floor joist size and spacing and beam sizes. Two copies of the property site plan showing the proposed deck to scale with dimensions to the property lines are also required.

FOOTINGS & POSTS

- All footings shall bear on solid ground 18" below grade. Footings and posts located in the backfill area of the house shall bear on undisturbed solid ground beneath the backfill. Footings typically need to be at least 4'-0" away from the house foundation wall to avoid the backfill

area. • Posts shall be a minimum 4x4 lumber. Posts over 8'-0" tall require 6x6 lumber and may require that knee bracing be installed.

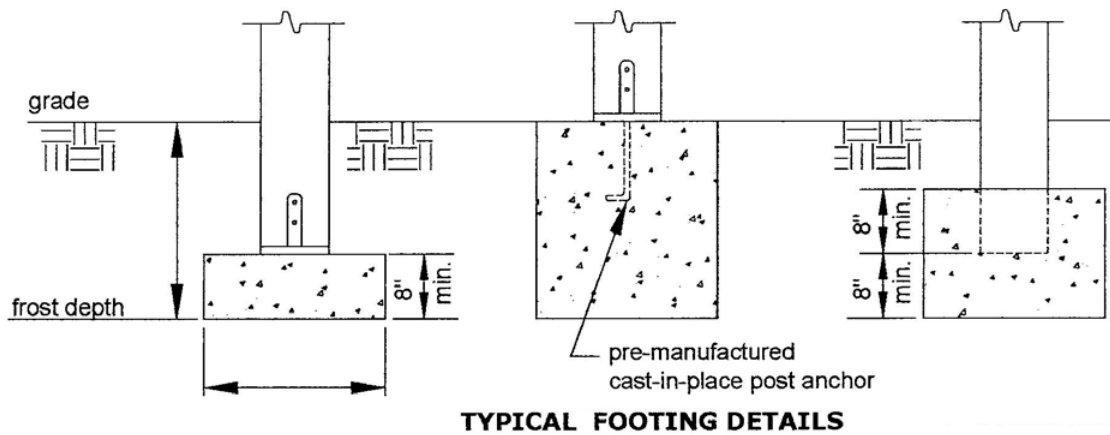

BEAMS

- The required beam size is based on the amount of tributary load carried by the beam, and on the distance between support posts. The maximum beam overhang is 2'-0" from the post.
- See page 6 for beam to post connection examples and additional information.

MAXIMUM BEAM SPANS									
40 LB/SQ. FT. Design Load - #2 Southern Pine									
BEAM SIZE	TRIBUTARY LOAD WIDTH (FT)								
	4'	5'	6'	7'	8'	9'	10'	11'	12'
	MAXIMUM BEAM SPAN								
(2) 2x6	7'	7'	6'	6'					
(2) 2x8	10'	9'	8'	7'	7'	6'	6'	6'	
(2) 2x10	12'	10'	10'	9'	8'	7'	7'	7'	7'
(2) 2x12	14'	12'	11'	10'	10'	9'	8'	8'	8'
(3) 2x8	12'	11'	10'	10'	9'	8'	8'	8'	7'
(3) 2x10	15'	14'	12'	11'	11'	10'	10'	9'	9'
(3) 2x12	16'	16'	15'	13'	13'	12'	11'	11'	10'

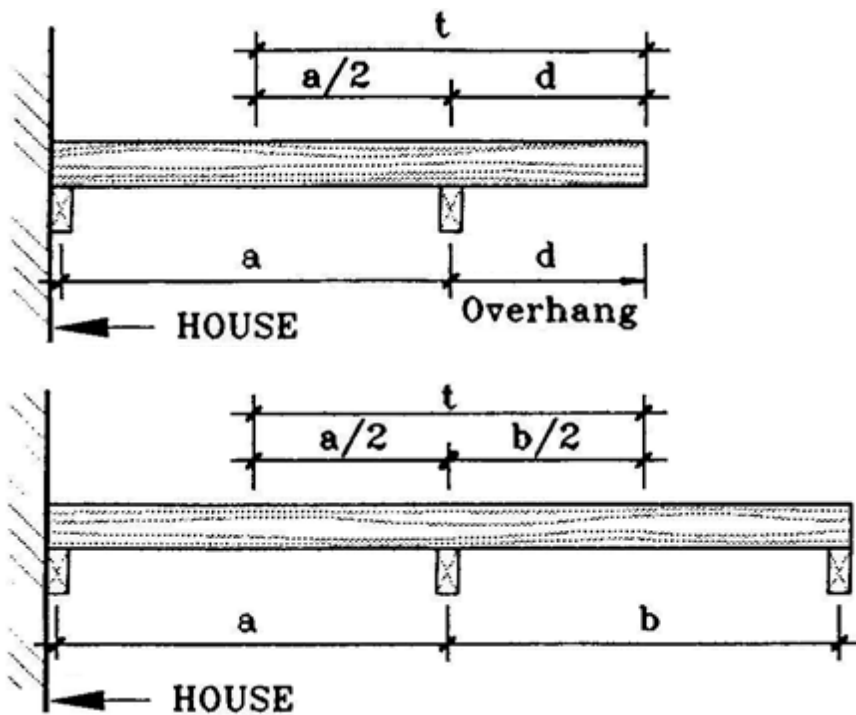

MAXIMUM JOIST SPANS			
40 LB/SQ. FT. Design Load			
#2 Southern Pine			
JOIST SIZE	JOIST SPACING (INCHES ON CENTER)		
	12"	16"	24"
2x6	10'-4"	9'-5"	7'-10"
2x8	13'-8"	12'-5"	10'-2"
2x10	17'-5"	15'-5"	12'-7"
2x12	20'-0"	17'-10"	14'-7"

JOISTS

- Joists may cantilever over the beam as follows: 2x6's – 1'-6" max. 2x8's – 2'-0" max. 2x10's – 2'-6" max. 2x12's – 3'-0" max. All cantilevered joist shall extend back a minimum of twice the cantilevered distance.

DECKING

- When using different species of lumber or composite material, follow the manufacturer's recommendations.
- To add strength to the deck structure, set decking at a 45 degree angle across the joist.

LEDGER

- Ledger board size shall be equal to or greater than the joist size and properly secured to solid structural material of the house. Nailing is not an acceptable method. See page 4 for examples.
- House siding must be removed prior to the installation of the ledger board. Flashing is required at any ledger board connection to a wall of wood framed construction. Flashing shall be composed of copper, stainless steel, UV resistant plastic or galvanized steel coated. Aluminum flashing will prematurely corrode due to the chemicals used in pressure treated lumber and shall not be used.
- Attachments to brick veneers, house overhangs or bay windows are prohibited. In such cases the deck shall be free standing or shall be designed by a Maryland licensed professional engineer.

LEDGER BOARD FASTENER SPACING			
JOIST SPAN	FASTENER SPACING - ON CENTER		
	Lag Screws 1/2" Dia.	LedgerLok	1/2" Thru-bolts (washers both sides), Expansion Anchors, Epoxy Anchors
0 - 6'-0"	30"	16"	36"
6'-1" - 8'-0"	23"	12"	36"
8'-1" - 10'-0"	18"	10"	34"
10'-1" - 12'-0"	15"	8"	29"
12'-1" - 14'-0"	13"	7"	24"
14'-1" - 16'-0"	11"	6"	21"
16'-1" - 18'-0"	10"	5"	19"

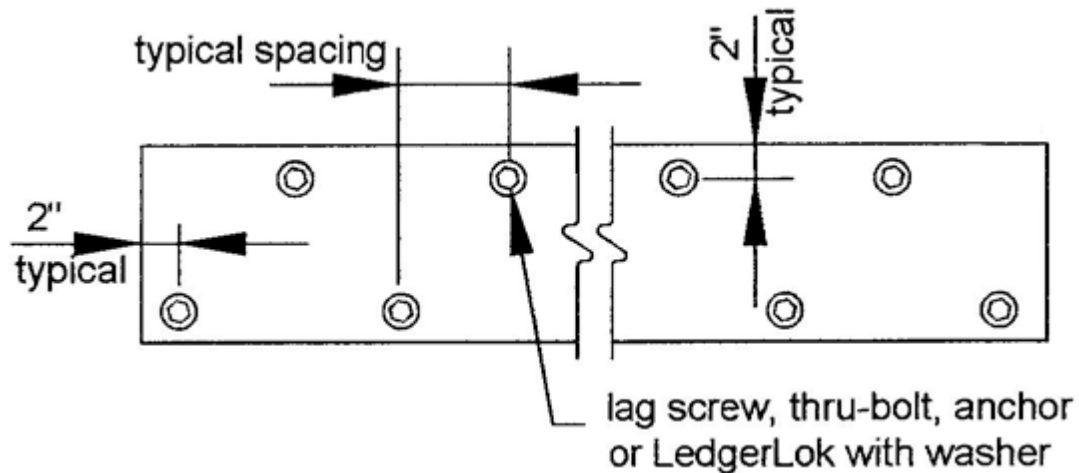

STAIRS & GUARDRAILS

- Minimum stair width is 3'-0". 10" min. tread, 7 3/4" max. riser
- Minimum ceiling height above the tread nosing is 6'-8". • Guardrails are required on decks over 30" above ground level. Minimum guardrail height is 36" above the decking. Railing system shall be able to resist a concentrated load of 200 lbs. at any point.
- Guardrails on stairs must be 34" min. height above the tread nosing.
- Guard opening limitations between members is 4" except at the triangular opening formed at stairs. A sphere 6" in diameter cannot pass through this area.
- Continuous graspable handrails on stairs shall be between 34" and 38" above the tread nosing and are required on stairs with 4 or more risers. Handrail ends shall be returned or terminate in newel post or safety terminals.

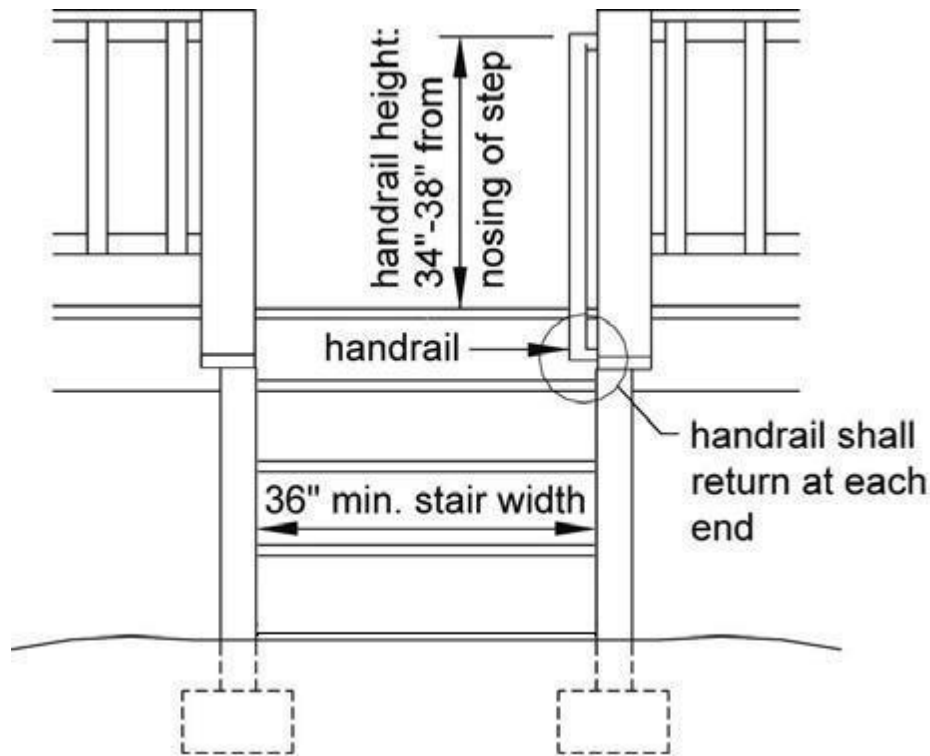
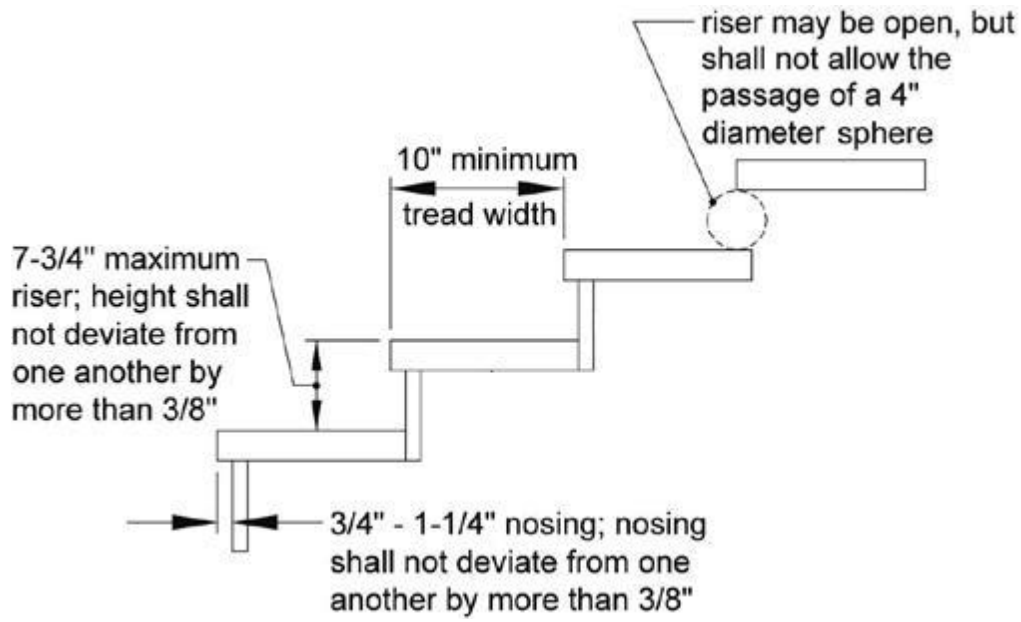

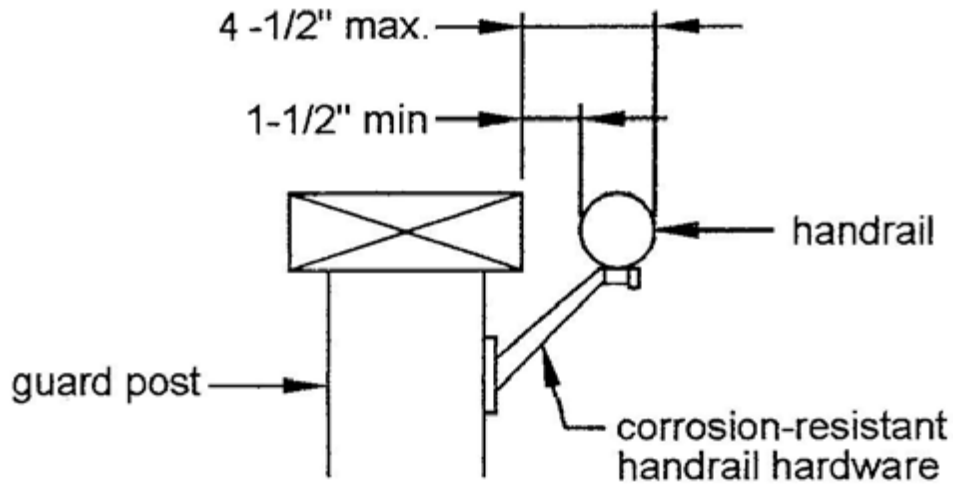

Handrail requirements: Note Handrail ends shall be returned into post or guardrail system

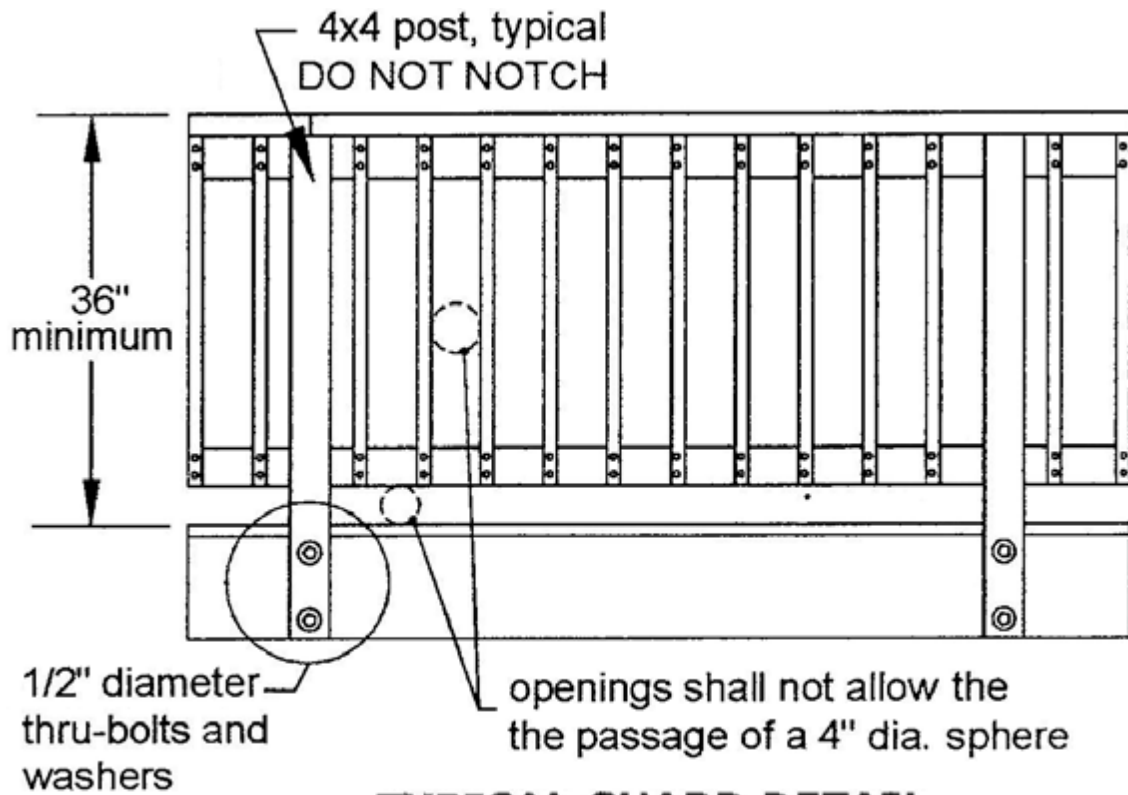

TYPICAL GUARD DETAIL

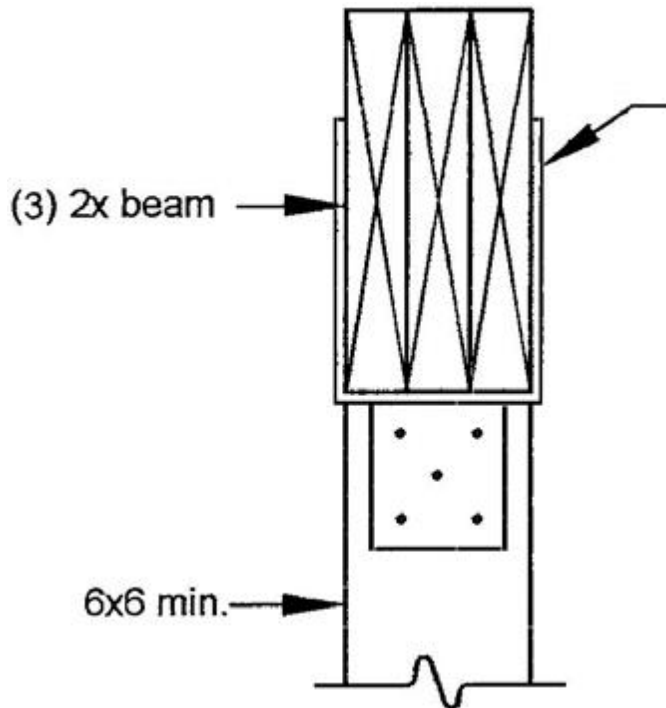
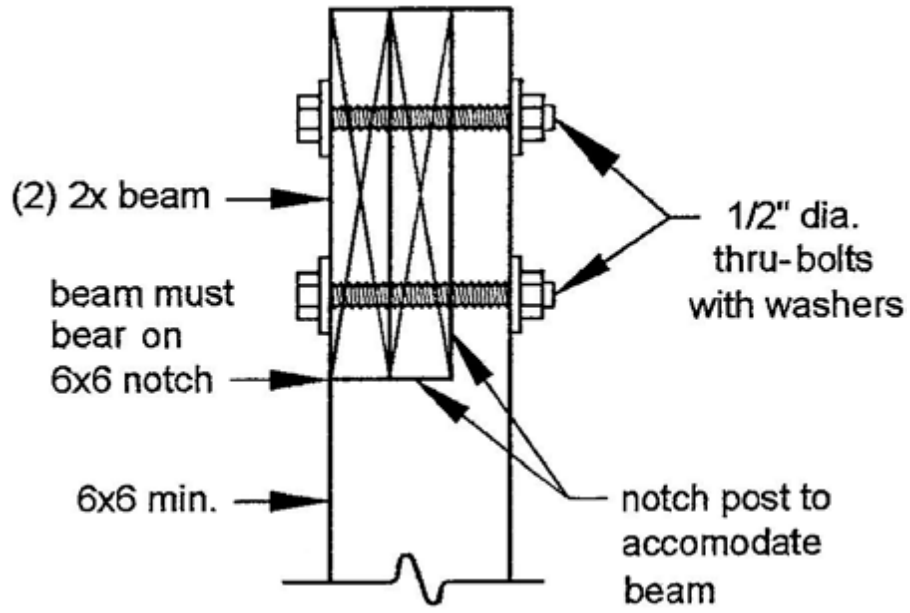

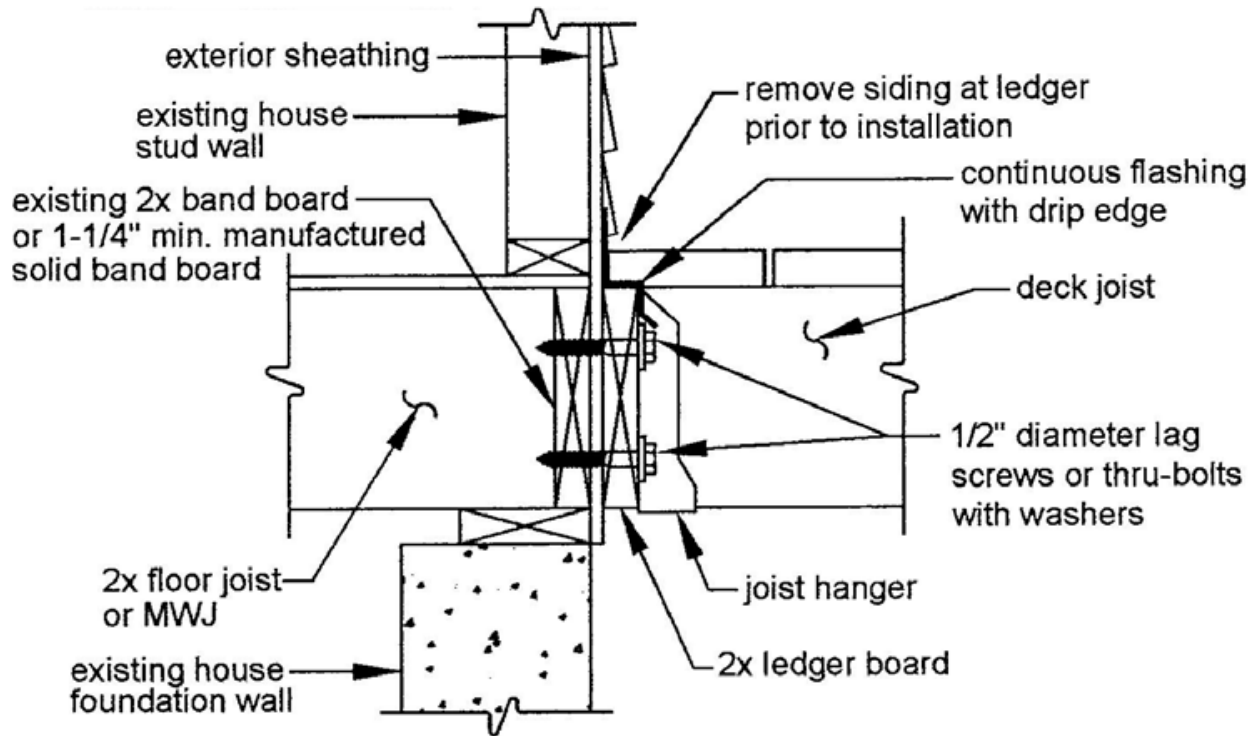

ATTACHMENT OF LEDGER BOARD-TO-BAND BOARD

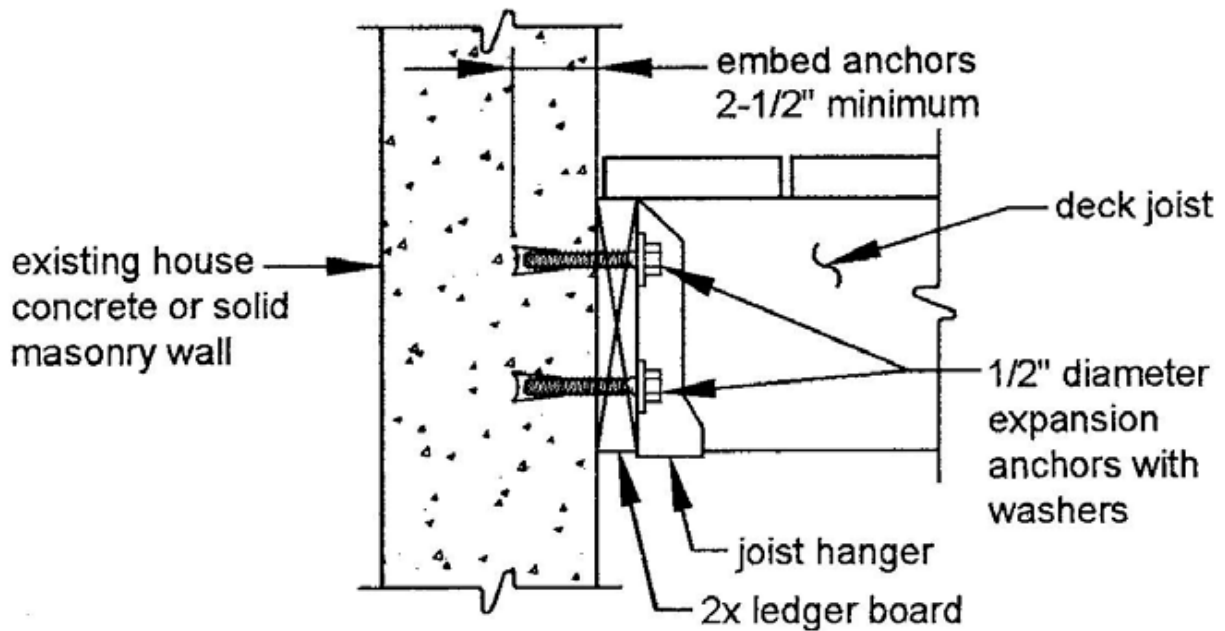

ATTACHMENT OF LEDGER BOARD-TO-FOUNDATION WALL (CONCRETE OR SOLID MASONRY)

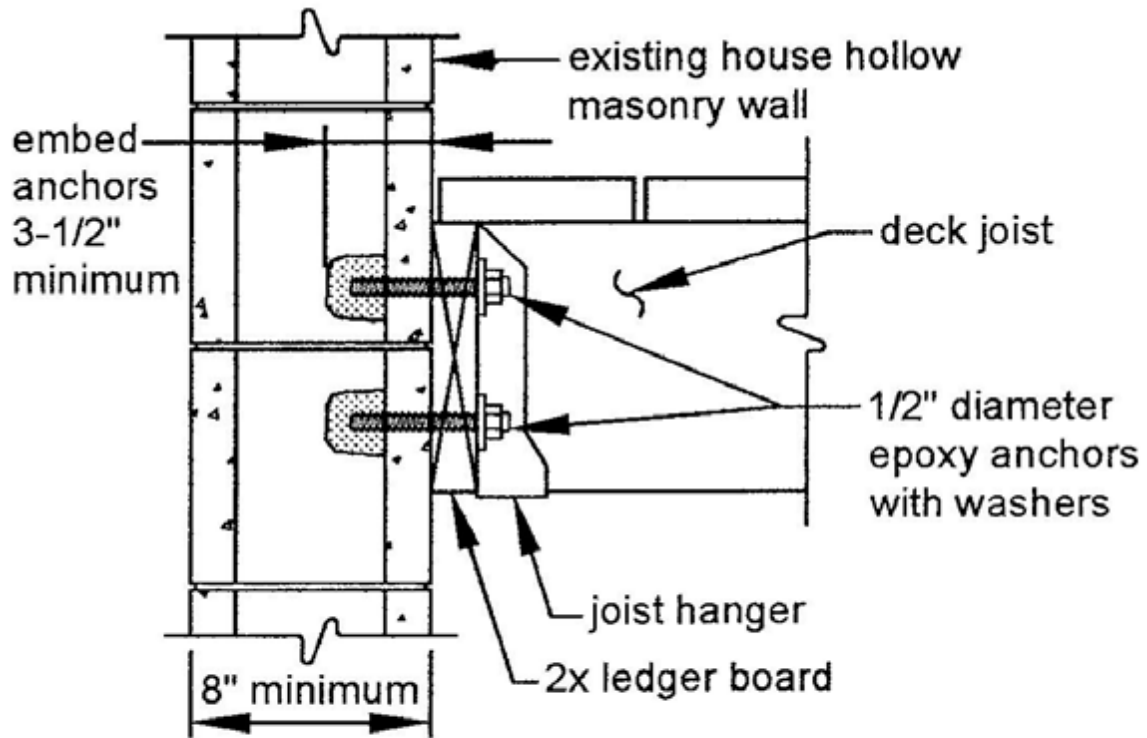

**ATTACHMENT OF LEDGER BOARD-TO-
FOUNDATION WALL (HOLLOW MASONRY)**